



ONE TEAM – ONE OUTCOME

# SEDAN UPDATE



www.speedwaysedans.com

SUPER SEDANS ONLY

July 2019

## 2019/2020 National Title

Super Sedans – Borderline Speedway SA  
Friday/Saturday/Sunday – 6/7/8 March 2020

## NEW SSA NATIONAL TITLE FORMAT RELEASED

Up to 40 Cars

Top 16 qualifying directly into A-Main

1 x B-Main – Top 6 transfer into the A-Main

22 Car Field to Decide the National Title

41-60 Cars

Top 16 qualifying directly into A-Main

2 x B-Mains Top 3 from each transfer into the A-Main

22 Car Field to Decide the National Title

61-80 Cars

Top 16 qualifying directly into A-Main

2 x B-Mains Top 3 from each transfer into the A-Main

1 x C-Main Top 2 transfer into the B-Mains

1<sup>st</sup> in C-Main goes to B-Main 1 and 2<sup>nd</sup> in C-Main goes

to B-Main 2

22 Car Field to Decide the National Title

81 Plus Cars

Top 16 qualifying directly into A-Main

2 x B-Mains Top 3 from each transfer into the A-Main

2 x C-Main Top 2 transfer into the B-Mains

22 Car Field to Decide the National Title

Updated Speedway Australia Racing Rules and Regulations effective July 2019. [Click Here](#)

All technical items mentioned in this newsletter can be found in the current updated Specification Book as uploaded to Speedway Sedans Australia website [Click Here](#)

## SECTION 2 ROLL CAGE MATERIAL & DESIGN OPTION

Effective for registration commencing 1 July 2019

[Click Here](#) for the Media Release

[Click Here](#) for the Full copy of Roll Cage Material &

Design Option

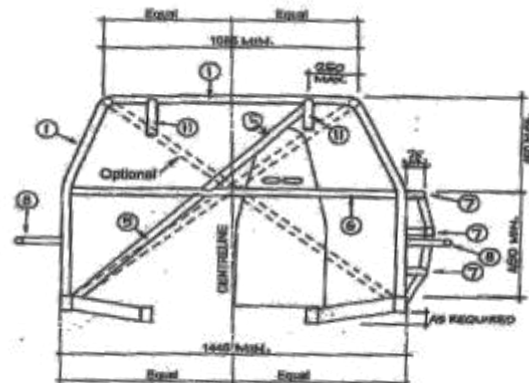
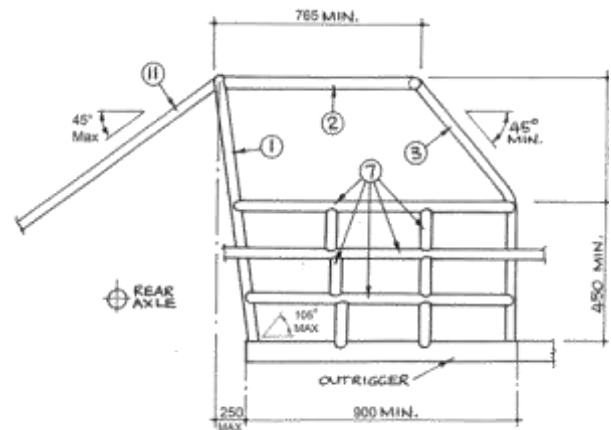
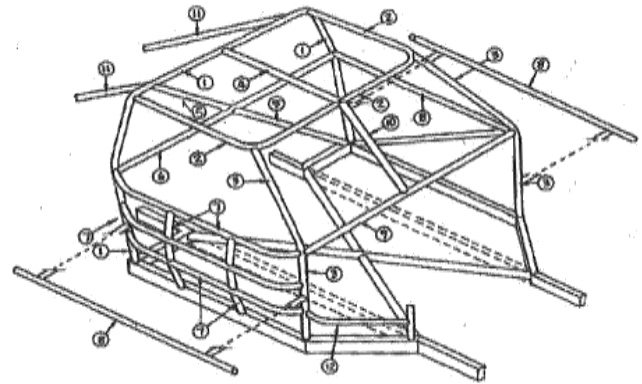

Note: Drawing for display purposes only. Refer to text for clarification on all drawings



**ONE TEAM – ONE OUTCOME**

# SEDAN UPDATE



[www.speedwaysedans.com](http://www.speedwaysedans.com)

**SUPER SEDANS ONLY** July 2019

Updates to General Super Sedan Specifications effective to all cars immediately.

## WINDOW NETS

Page 8 Section 14 c)

Modifications such as cutting, drilling or hole punching the window net material to facilitate attachment is NOT permitted.

## Materials Permitted:

Page 11

Additional material included

Chrome Moly 4130

For construction of Roll Cages

## WEIGHT LIMITS

Page 11

Inclusion of weight minimum for cars using CT 525 Engine – 1000kg (2200lbs)

## TOWING ATTACHMENTS

Page 27

c) The use of the fuel tank protection bar or protection bar supports as a towing point at rear of car is NOT permitted. Tow straps MUST be fitted to the front and rear of the vehicle.

## ENGINE SEALING

Section 24 Engine and Engine Systems

Page 29

- a) Engines MUST be sealed using two SSA numbered blue tool less roto seals, and one yellow SSA engine ID tag. Sump and timing cover are to be sealed with SSA ID tag being attached with the timing cover seal. Current Engine seal sheet to be kept with the current car registration log book at ALL times.
- b) CT525 engines that have been purchased new from an approved engine supplier, will require a yellow ID tag ONLY.
- c) Copies of original purchase invoice and shipping documentation verifying the authenticity of the engine shall be provided to the registered SSA engine sealer for approval prior to SSA ID tagging a new CT525 engine.
- d) Genuine GM factory seals fitted to new CT525 engines by an approved supplier will be recognised as the engine being compliant to CT525 specification.

Upon the removal of GM factory seals for engine reconditioning, nominal SSA engine sealing procedure will apply. Refer engine capacity.

## IGNITION & BATTERY AND ELECTRICAL SYSTEM

Page 31 c) AND Page 34 h)

An engine 'KILL' switch, suitably and clearly marked for method of operation, to be mounted centrally in decking at front of driver. ONLY lever/twist type kill switches permitted. This switch must also isolate the battery and any other electrical item.

Contact your State Divisions CTAC Representative or your State Technical Representative for further information.

Ron Bergmeier – CTAC Chairman – 0418 509 817

[ron@bergmeier.com.au](mailto:ron@bergmeier.com.au)

VIC – Mick Nicola – 0418 514 444 –

[mick@tcc.net.au](mailto:mick@tcc.net.au)

NSW – Andrew White – 0438 680 613 –

[andrew@kingbros.net.au](mailto:andrew@kingbros.net.au)

SA – Peter Lowe – 0417 802 380 –

[lrcandt@bigpond.net](mailto:lrcandt@bigpond.net)

WA – Tristan Green – 0411 429 156 –

[tristang@iprimus.com.au](mailto:tristang@iprimus.com.au)

TAS – Brett Davidson – 0408 332 821 –

[brett.davidso61@outlook.com](mailto:brett.davidso61@outlook.com)

QLD – Doug Rigby (Acting) – 0413 649 889 –

[statetech@gsca.com.au](mailto:statetech@gsca.com.au)

## SPEEDWAY SEDANS AUSTRALIA CONTACT DETAILS

National Office – [office@speedwaysedans.com](mailto:office@speedwaysedans.com)

Technical – [technical@speedwaysedans.com](mailto:technical@speedwaysedans.com)

Postal – P.O. Box 163, HOLDEN HILL SA 5088